

## Fukasawa 2 Hole Basin Mixer

Code: A104WF

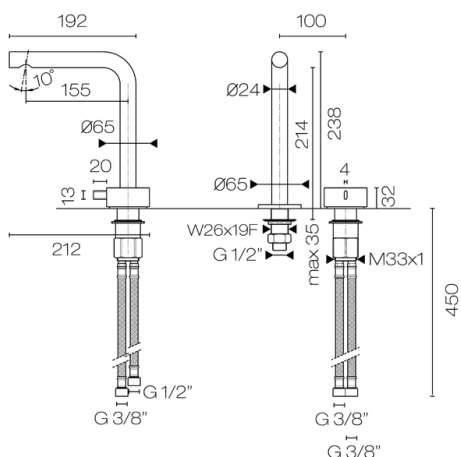

<b>Brand</b>	Fantini
<b>Designer</b>	Naoto Fukasawa
<b>Installation</b>	Bench Mount
<b>WELS Rating</b>	5 Stars
<b>Spout Reach (mm)</b>	155
<b>Height (mm)</b>	238
<b>Warranty</b>	20 Years
<b>Notes</b>	Suits mains pressure. Progressive cartridge - by turning the mixer handle in a clockwise direction the temperature increases while the water flow remains the same
<b>Other Information</b>	Lead free: In compliance with the most progressive international standards safeguarding public health, the Fukasawa faucet surface in contact with drinking water does not exceed 0.25% in lead content
<b>Cleaning and Maintenance</b>	Use hot soapy water and a smooth cloth to clean all surfaces. Do not use abrasive sponges or detergents as these will damage the finishes.



Scan to View  
Product Online



## Fukasawa 2 Hole Basin Mixer

Code: A104WF

### Building Product Information Requirements (BPIR)

<b>Manufacturer</b>	Plumblinc
<b>Building Code Clauses</b>	G12 (Water Supply) Performance Clause G12.2.1 / B2 (Durability) B2.3.1 (c)
<b>Compliance Evidence</b>	This product complies with the clauses B2.3.1 (c) and G12.2.1. The product has an in-service history of 6+ years and has industry-leading performance qualities. Compliance is as per verification method B2/VM1. The cartridge has ISO 9001 & ASNZS 4020: 2018 certification.
<b>Condition of Use</b>	For use in residential and commercial applications. Must be installed by a registered plumber or suitably qualified tradesperson and as per the installation instructions.
<b>Version no.</b>	1.0
<b>Subject to a Warning</b>	No

Scan to View  
Product Online

